



**EUPEN** Cable USA

# CONNECTOR INSTALLATION MANUAL

50 Ohm Coaxial, Elliptical Waveguide, Radiating

**INNOVATION & TRADITION**

100 Years of Cable Manufacturing

Ph: 800-419-5100 Fax: 727-528-0751  
5181 110th Ave N, Unit D, Clearwater, FL 33760  
[www.eupen.us](http://www.eupen.us) [customerservice@eupen.us](mailto:customerservice@eupen.us)



## About this Manual

This connector installation manual will give installers a step by step instruction on how to properly install Eupen 50 Ohm Coaxial, Elliptical Waveguide and Radiating connectors. This will include different methods of installation by the use of common hand tools and or automated tooling. Any liability or responsibility for the results of improper or unsafe installation is here by disclaimed.

Contact **Eupen Cable USA, Inc.** for field support at **1-800-419-5100**  
or on the web **[www.eupen.us](http://www.eupen.us)**



### *Certificate of Training*

THIS IS TO CERTIFY

The holder of this certificate has successfully completed  
**The Eupen Authorized**

- Coax Training Course
- Elliptical Waveguide Training Course
- Hybrid Fiber Training Course

100 Years of Cable Manufacturing  
**INNOVATION & TRADITION**  
Cables | Connectors | Tools | Jumpers | Site Accessories  
5181 110th Ave N Unit D, Clearwater, FL 33760



## Safety Precautions

Safety on the job site must be the primary consideration and top priority at all times. Before beginning any installation, the appropriate OSHA safety guidelines should be reviewed with all onsite personnel and adhered to at all times. All personnel must wear the appropriate construction safety gear including gloves and eye protection at all times.



# CONTENTS

Best Practices and Technical Documents .....	Section 1
50 Ohm Coaxial Connectors .....	Section 2
Elliptical Waveguide Connectors .....	Section 3
Radiating Connectors .....	Section 4
Cable Products Reference Sheets .....	Section 5





# BEST PRACTICES AND TECHNICAL DOCUMENTS

## SECTION 1

Best Practices for PIM Performance .....	1
Torque Wrench Specification Guide .....	1
Connector Cleaning .....	1
Coupler Nut Torque Specifications .....	2
Attaching Connector Couplers Instructions .....	2



## BEST PRACTICES

There are a few common practices that can be applied when installing connectors to ensure PIM does not become an issue.

**Dirty Tools** - tools should be inspected prior to use to ensure they are free of grease, dirt, and debris and cleaned if necessary.

**Bent Cable Ends** - cable end should be straight and cut in the valley before connector installation.

**Center Conductor** - center conductor should be free from scrapes and properly chamfered (see picture below).

**Contaminated Dielectric** - dielectric should be inspected to ensure it is free of grease, dirt and debris and cleaned if necessary

**Torque Specifications** - proper torque wrenches should be used to ensure sufficient contact pressure is achieved.

**Contaminated Contacts** - connector interfaces should be cleaned before mated to each other.



## TORQUE WRENCH SPECIFICATION GUIDE

CONNECTOR BACK NUTS		
Cable Type	Connector Torque Specification	Torque Wrench
EC4-50-HF	20 ft lbs	TQ-34-F20
EC4-50	20 ft lbs	TQ-34-F20
EC5-50-A	22 ft lbs	TQ-30MM-F22
EC6-50-A	29 ft lbs	TQ-11116-F29
EC7-50-A	37 ft lbs	TQ-214-F37
Connector Interface		
Interface Type	Interface Torque Specification	Torque Wrench
N	7 ft lbs	TQ-34-F7
4.1-9.5	11 ft lbs	TQ-78-F11
7-16 DIN	18 ft lbs	TQ-114-F18-M
4.3-10	6 ft lbs	TQ-78-F6

### Cleaning Connector Interfaces

Using alcohol pads containing 70% isopropyl alcohol, clean the inside of the connector interface to include the centerpin and dielectric. Ensure that all dust, dirt and debris are removed before mating connectors. Clean compressed air can be used to remove any residual alcohol.



# TECHNICAL DOCUMENT

## ATTACHING CONNECTOR COUPLERS

Style	Torque Specification	Torque Wrench Part Number	Connector Body Size (standard)	Connector Body Size (Hiflex)
"N"	7 ft lbs	TQ-34-F7	19 mm	19 mm
"4.1-9.5"	11 ft lbs	TQ-78-F11	19 mm	N/A
"7/16 Din"	18 ft lbs	TQ-114-F18-M	21 mm	21 mm
"4.3- Din"	6 ft lbs	TQ-78-F6	21 mm	N/A

Please note standard and hiflex right angle connector bodies require an 24mm open ended wrench



Step 1 - Attach coupler nut finger tight



Step 2 - With an open ended wrench hold connector body in a fixed position



Step 3 - Use torque wrench to tighten coupler nut until the wrench handle "clicks", at this point the proper torque has been applied



Step 4 - Remove wrench and torque wrench

# **50 Ohm Coaxial Connector Installation Instructions**

---

## **SECTION 2**

**EC1-50- HF 1/4"**

**EC4-50-HF 1/2"**

**EC1-50 1/4"**

**EC4-50 1/2"**

**EC4-50-PL 1/2"**

**EC4.5-50 5/8"**

**EC5-50 A 7/8"**

**EC6-50 A 1-1/4"**

**EC7-50A 1-5/8"**

**EIA Flange Connector EC4-50 1/2"**

**EIA Flange Connector for 7/8" to 1-5/8"**



# INSTALLATION INSTRUCTIONS

... B1/4X & ... BL1/4X & ... P1/4X CONNECTORS

Rev. 04/2016-11-30



	NM - NFP - NM 90°	7/16M	7/16M 90°
	2 x 16mm + 19mm	16 mm + 24 mm + 32 mm	16 mm + 23 mm + 32 mm

## A + B

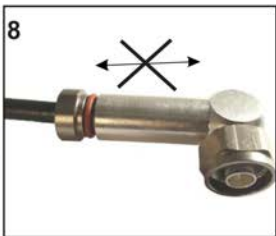
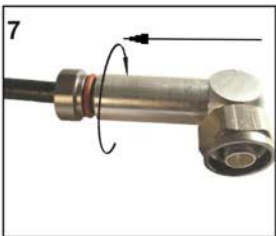
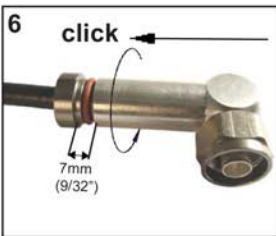
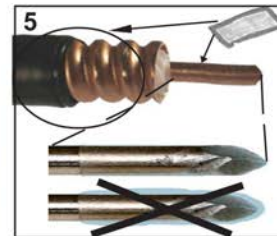
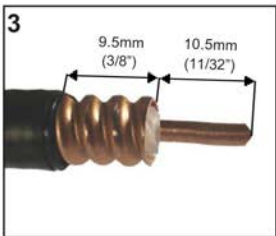
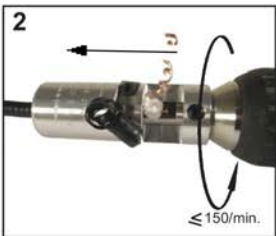
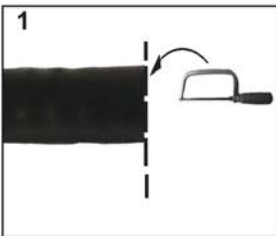

CE

## B + C

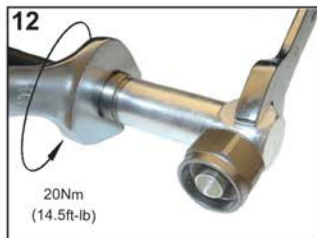
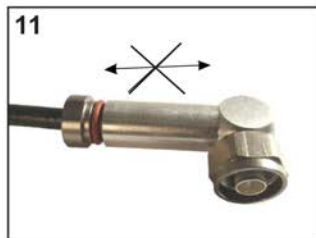
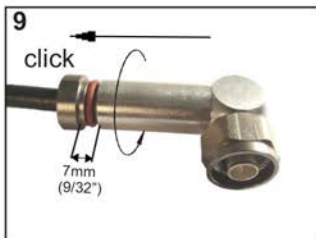
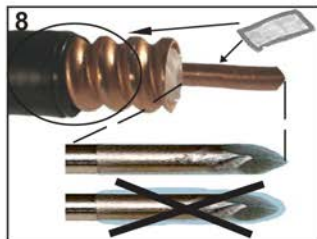
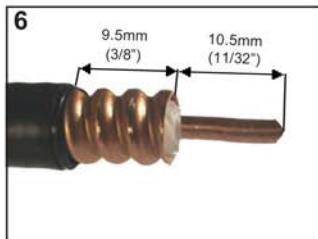
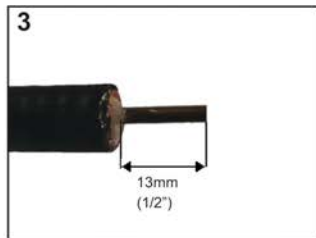
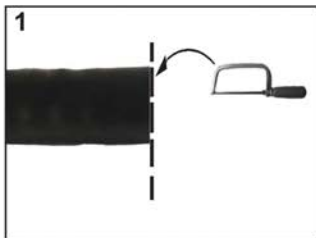



# INNOVATION & TRADITION

100 Years of Cable Manufacturing

## 1/2" X (1/2" HIFLEX) - straight connectors



1/2"X	SPTC50B12X

	NF, NM	7/16M	7/16F
	2 x 19 mm	19 mm & 21 mm & 32 mm	19 mm & 21 mm



### PREPARATION TOOL METHOD

**1**

**2**

SPTC50B12X

**3**

10 mm 9.5 mm  
0.390" 0.370"

**4**

3M: F 04/013

**5**

**6**

7 mm 0.27"

click

**7**

**8**

**9**

27 Nm  
(20 ft-lb)

**10**

(D) Verarbeitung nur durch eine Elektrofachkraft. Es besteht die Gefahr eines elektrischen Schlages!

(F) Installation uniquement par une personne qualifiée en électricité. Il y a un risque de choc électrique!

(NL) Installatie alleen door een vakman voor elektriciteit. Er is gevaar van elektrische schok!

(GB) Processing only by a qualified electrician. There is a risk of electric shock!

Preparation drawing: 1:1



## 1/2" X (1/2" HIFLEX) - right angle connectors



	
1/2"X	SPTC50BL12X

	NM	7/16M
	19 mm & 23 mm	19 mm & 23 mm & 32 mm



### PREPARATION TOOL METHOD

1. Cut the cable with a hand saw.
2. Strip the outer jacket with SPTC50BL12X.
3. Strip the inner insulation to 11 mm (0.429") and 12 mm (0.468").
4. Clean the copper strands with 3M F 04/013 abrasive.
5. Apply Vaseline to the copper strands.
6. Insert the cable into the connector, ensuring a 7 mm (0.27") gap and a 'click' sound.
7. Tighten the connector.
8. Do not over-tighten (indicated by a red X).
9. Final tightening to 27 Nm (20 ft-lb).
10. Final assembly check.

(D) Verarbeitung nur durch eine Elektrofachkraft. Es besteht die Gefahr eines elektrischen Schlages!

(F) Installation uniquement par une personne qualifiée en électricité. Il y a un risque de choc électrique!

(NL) Installatie alleen door een vakman voor elektriciteit. Er is gevaar van elektrische schok!

(GB) Processing only by a qualified electrician. There is a risk of electric shock!

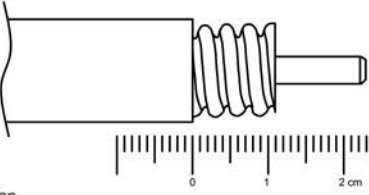

Preparation drawing: 1:1

# INNOVATION & TRADITION

100 Years of Cable Manufacturing

## INSTALLATION INSTRUCTIONS

... A 1/4 & ... A L 1/4 CONNECTORS



	NM - NF	NML
	2 x 14mm + 1 x 19mm	1 x 14mm + 1 x 19mm + 1 x 16mm

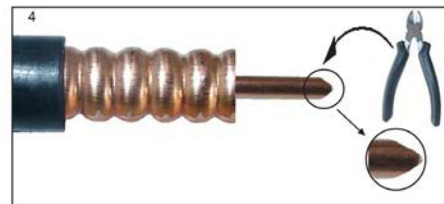
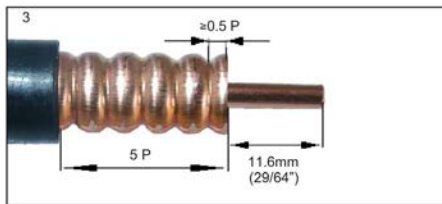
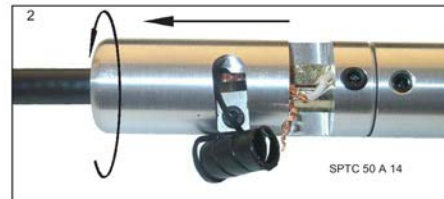
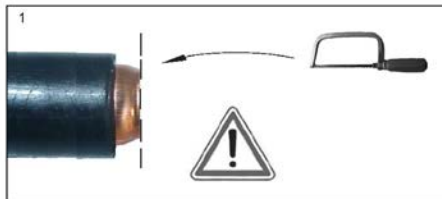

CE

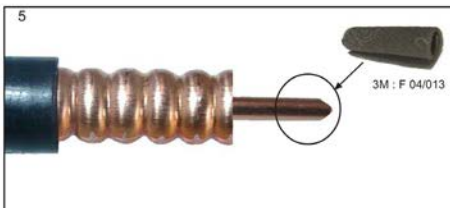



## 1/2" - Straight & right angle connectors - O-Ring type



EC4-50 (5128) EA4-50 (5127)	<b>SPTC50AV12</b>

Please use the cable preparation tool SPTC50AV12 and refer to its instructions for use.

Follow the instruction process below only if the tool SPTC50AV12 is not available.

Vaseline  
Vaselina  
凡士林

3M : F 04/013  
Abrasive  
Schleifmittel  
Schnuurpons  
Abrasive  
磨砂纸

	NF, NM	NM50VL12	4.3/10M N1	7/16M N1	7/16MVL12	7/16F N1 4.3/10F N1
	2 x 19 mm	19 mm & 23 mm	19 mm & 21 mm & 22 mm	19 mm & 21 mm & 32 mm	19 mm & 24 mm & 32 mm	19 mm & 21 mm

### MANUAL METHOD

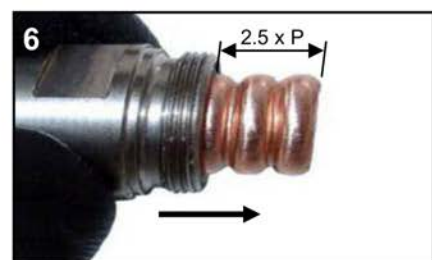
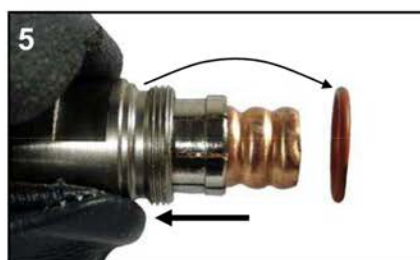
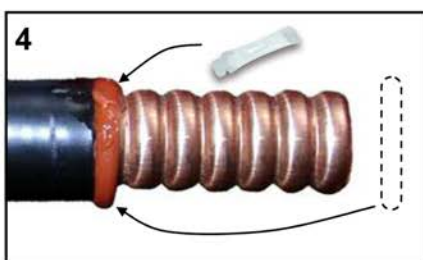
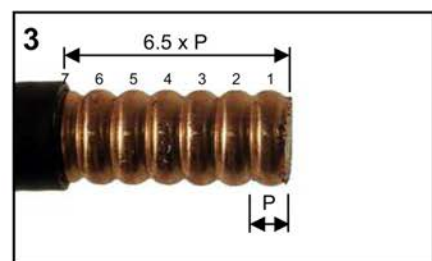
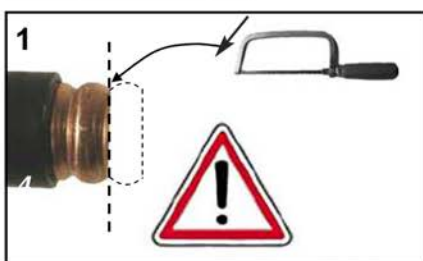

# INNOVATION & TRADITION

100 Years of Cable Manufacturing

## 1/2" - Straight & right angle connectors - O-Ring type

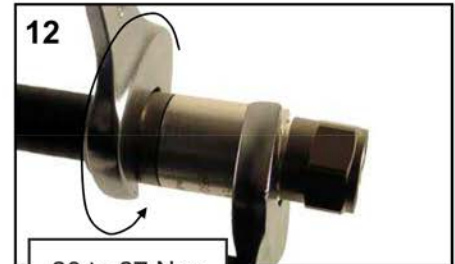
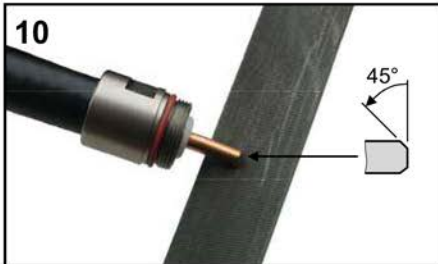
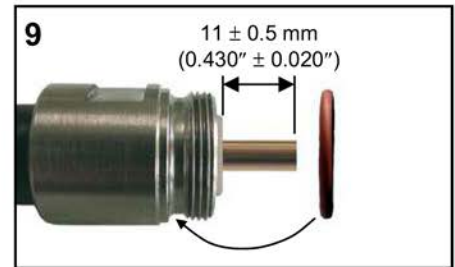
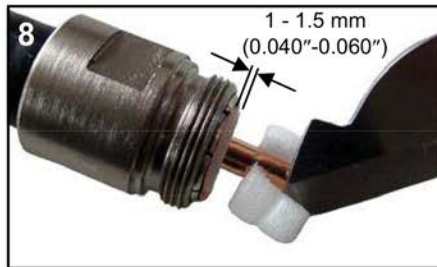
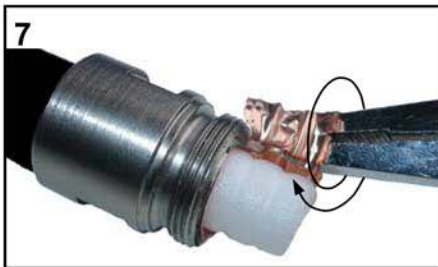

For installation on aluminium cable 5127/EA4-50 in a corrosive environment, an additional sealing is mandatory. It can be achieved with one of the following methods:

Weatherproofing Tape Kit



Eucaseal



Cold Shrink Tube





## SPTC 50 AV 1/2



for cables EC4-50 (5128) and EA4-50 (5127)

	NF, NM	NM50VL12	4.3/10M N1	7/16M N1	7/16MVL12	7/16F N1 4.3/10F N1	EIA
	2 x 19 mm	19 mm & 23 mm	19 mm & 21 mm & 22 mm	19 mm & 21 mm & 32 mm	19 mm & 24 mm & 32 mm	19 mm & 21 mm	2 x 10 mm & 19 mm & 24 mm

### PREPARATION TOOL METHOD

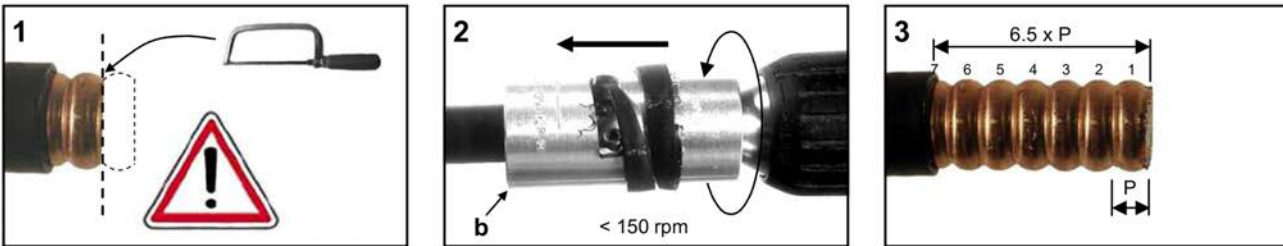

### O-RING CONNECTORS

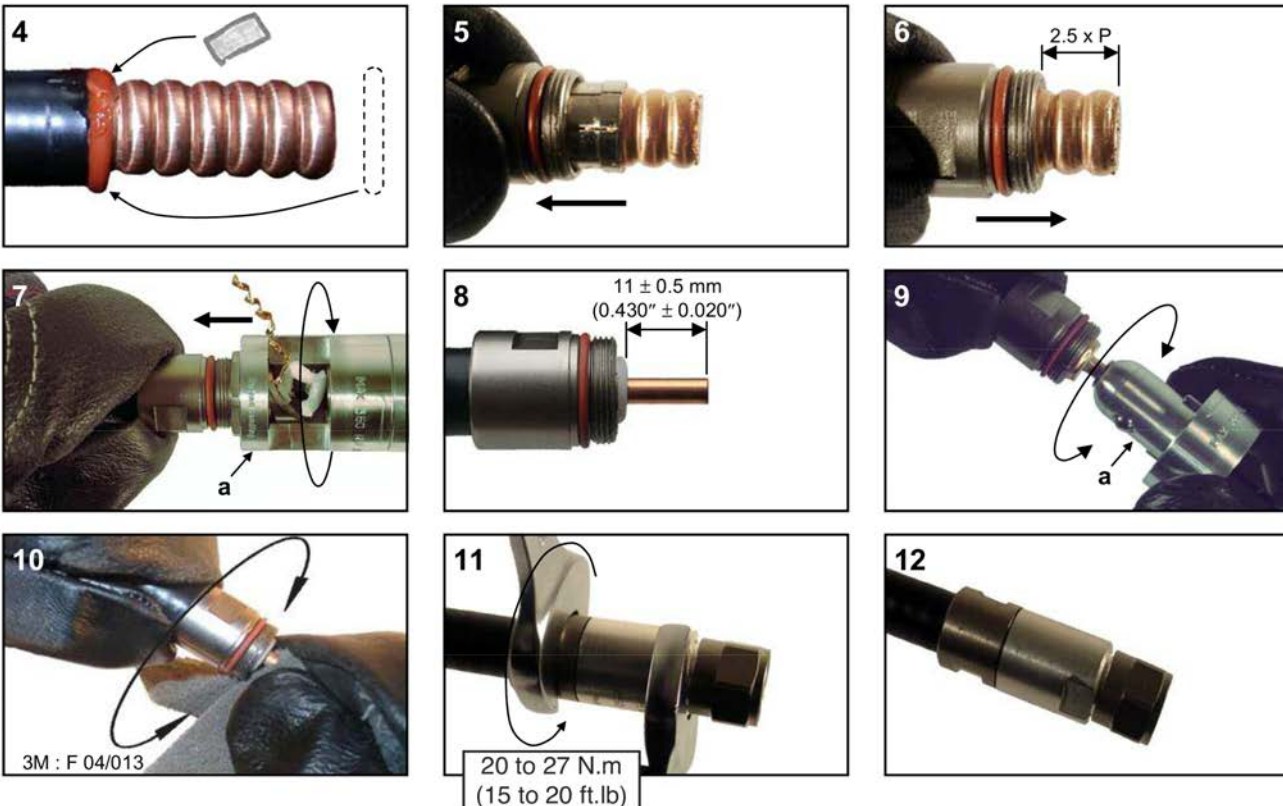

# INNOVATION & TRADITION

100 Years of Cable Manufacturing

For the installation on cable 5127/EA4-50, an additional sealing is mandatory. It can be achieved with one of the following methods:

Weatherproofing Tape Kit



Eucaseal



Cold Shrink Tube



Order code for the tool and replacement parts

Code de l'outil et des pièces de rechange

Bestelcode van het gereedschap en van zijn wisselstukken

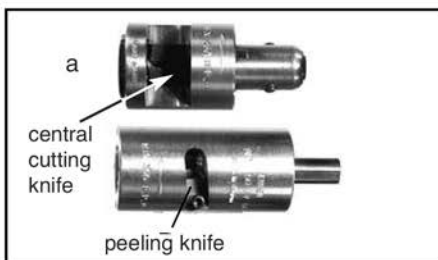

Description Description Beschrijving	Reference Référence Verwijzing	Part# Code# Bestel#
Tool - 1/2"	SPTC50AV12	A032 996
Cutting tool (a)*	CFT50AV12	F933 996
Central cutting knife**		A257 996
Peeling knife		A256 996

\* complete front part including central cutting knife

\*\* delivered with instructions for knife replacement



## 1/2" - Straight & right angle connectors - O-Ring type Installation on Plenum cable 5129-PL (EC4-50-PL)



### Procedure for manual installation



	NF, NM	NM50VL12	7/16M N1	7/16MVL12	7/16F N1	EIA
	2 x 19 mm	19 mm & 23 mm	19 mm & 21 mm & 32 mm	19 mm & 24 mm & 32 mm	19 mm & 21 mm	2 x 10 mm & 19 mm & 24 mm

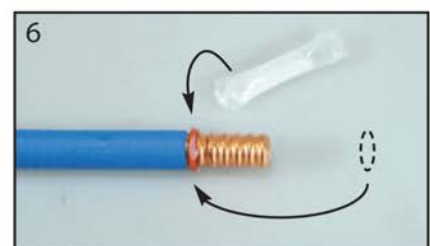
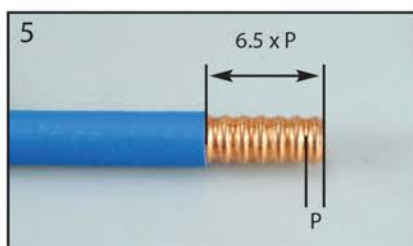
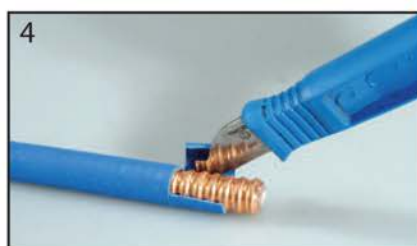



# INNOVATION & TRADITION

100 Years of Cable Manufacturing

## 1/2" - Straight & right angle connectors - O-Ring type Installation on Plenum cable 5129-PL (EC4-50-PL)

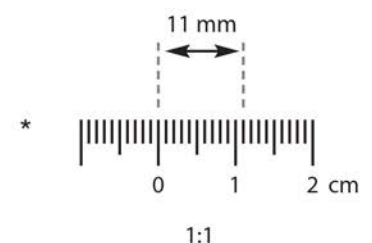
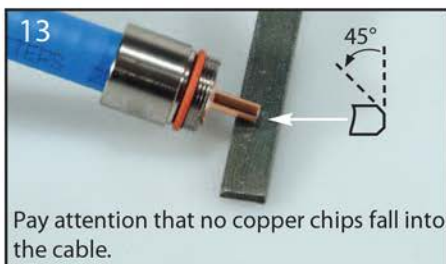
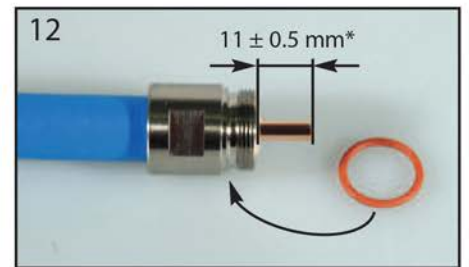
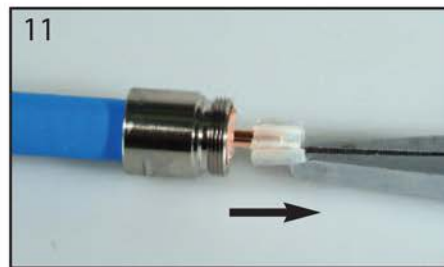
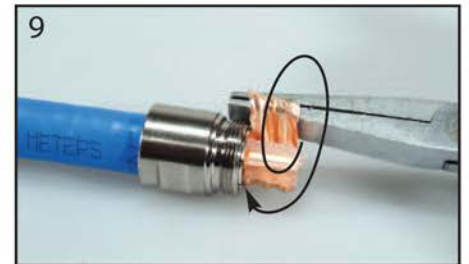
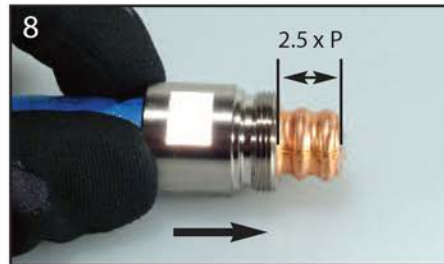
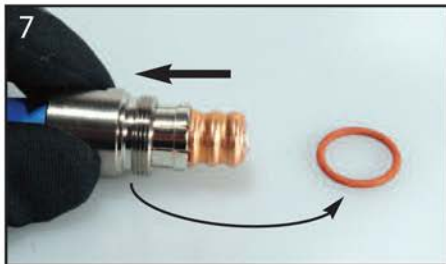

## SPTC 50 AV 1/2F

Cable preparation tool for installation of 1/2" connectors on Plenum-rated cable EUPEN 5129-PL.



### Required equipment



≥14 V

	NF, NM	NM50VL12	7/16M N1	7/16MVL12	7/16F N1	EIA
	2 x 19 mm	19 mm & 23 mm	19 mm & 21 mm & 32 mm	19 mm & 24 mm & 32 mm	19 mm & 21 mm	2 x 10 mm & 19 mm & 24 mm

**NB:** always pay attention that no copper chips fall into the cable



Never use a saw with the cable 5129-PL.

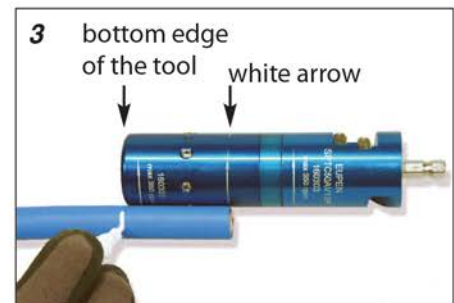

# INNOVATION & TRADITION

100 Years of Cable Manufacturing

## SPTC 50 AV 1/2F

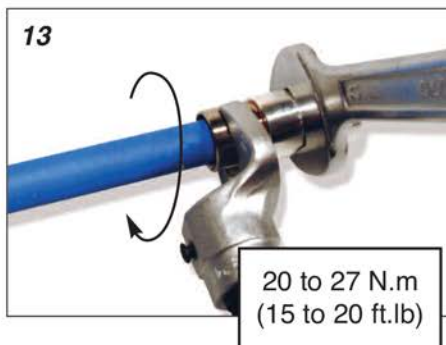
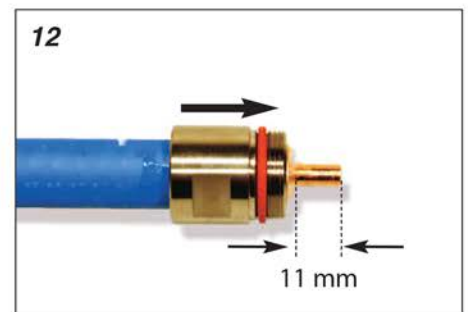
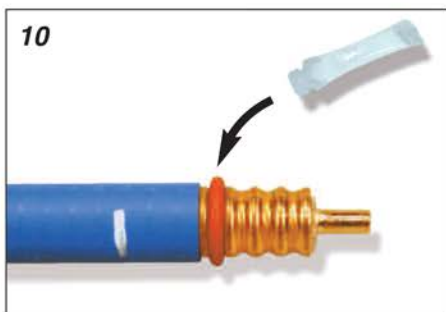
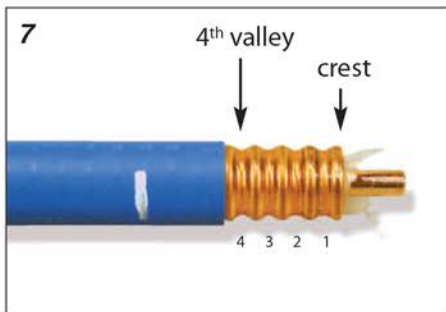
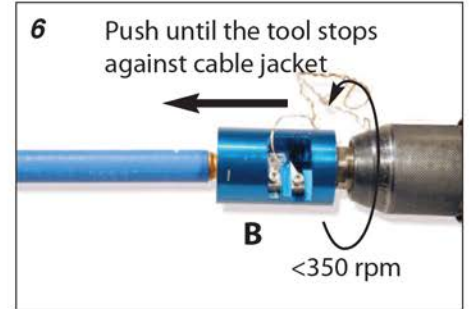
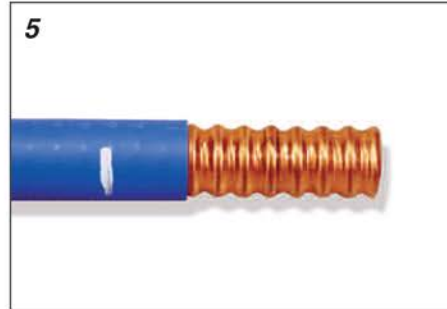
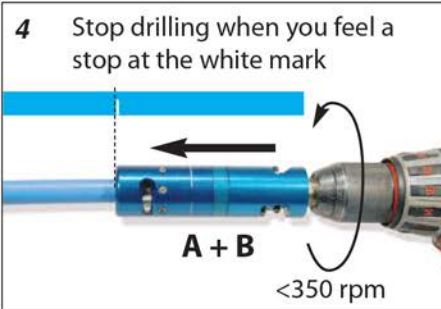



## 5/8" Connectors - O-Ring type



NF50V58



NM50V58

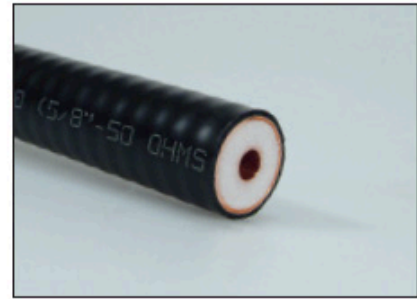

5/8"

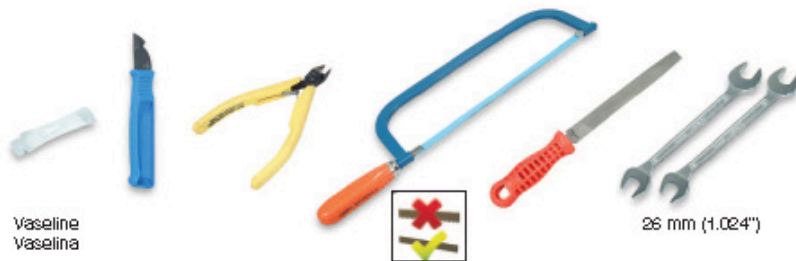

Vaseline  
Vaselina

26 mm (1.024")

### Manual method

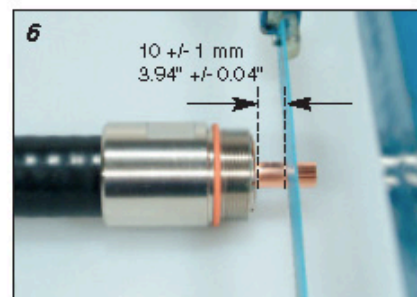
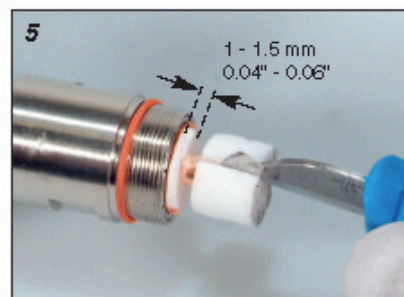
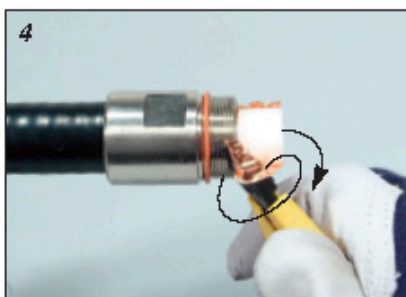
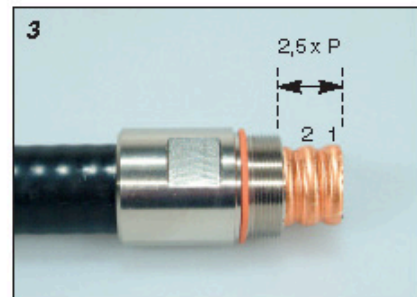
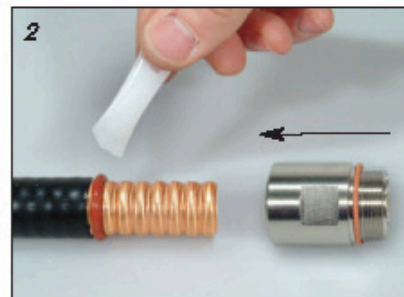
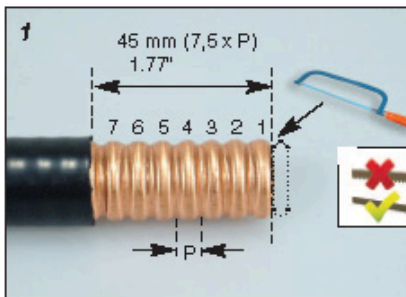

# INNOVATION & TRADITION

100 Years of Cable Manufacturing

## 5/8" Connectors - O-Ring type

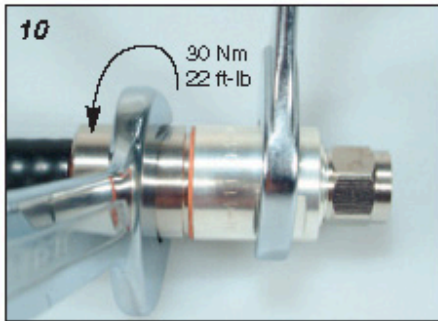
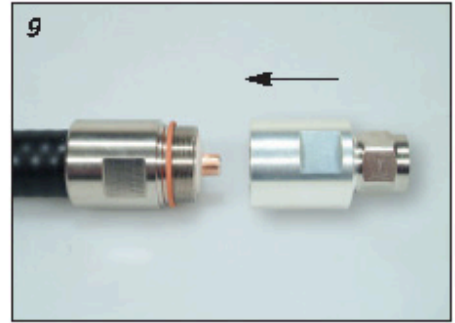
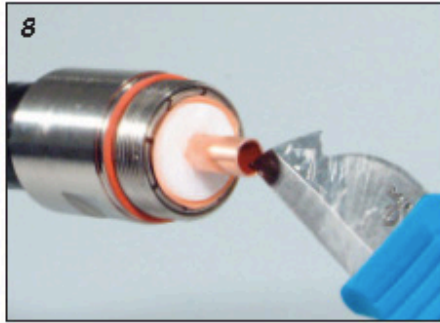
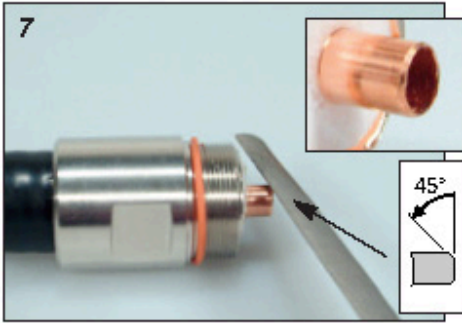



# EUPEN Cable USA

## SPTC 50 V 58



for cable EC4.5-50 (5168)

### Required equipment



5/8"  
26 mm  
(1,024")

NM  
19 mm  
(3/4")

### Instruction process

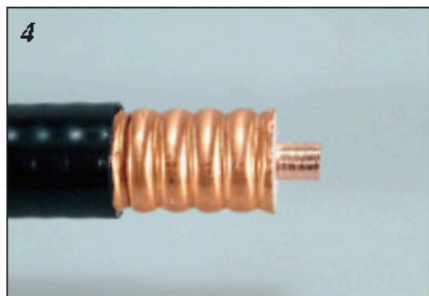
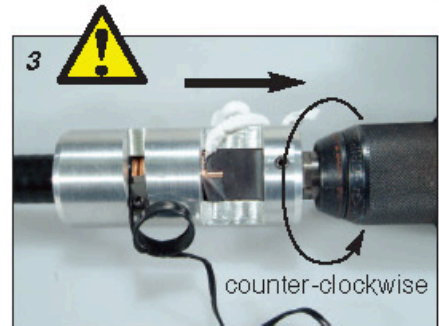
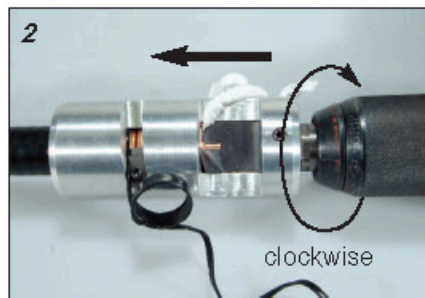
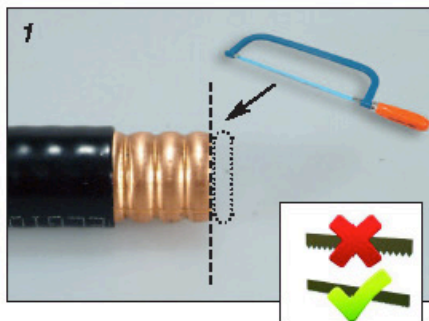

# INNOVATION & TRADITION

100 Years of Cable Manufacturing

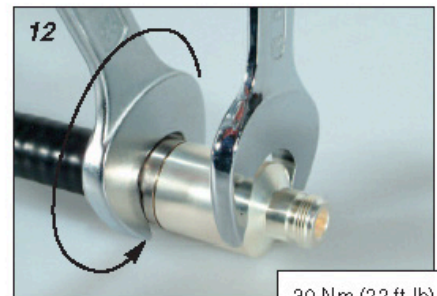
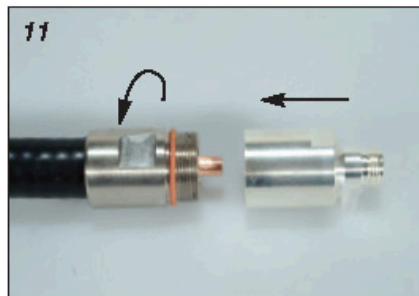
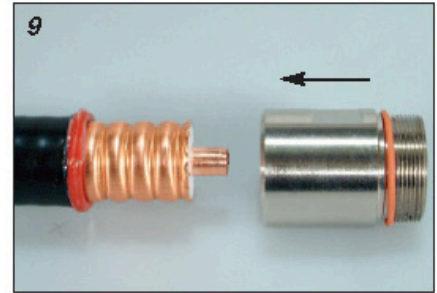
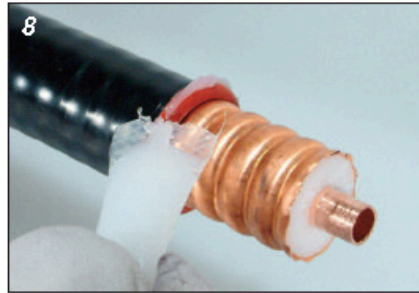
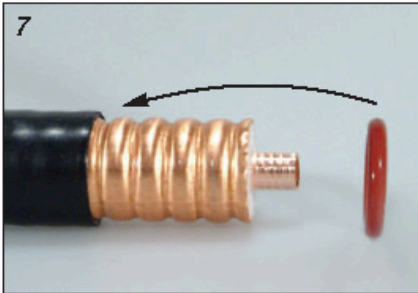



30 Nm (22 ft-lb)





## 7/8", 1-1/4" & 1-5/8" Connectors - N1 (O-ring)



Cable	Preparation tool
 5228A / EC5-50-A (7/8") 5227 / EA5-50 (7/8" Alu)	 SPTC50AV78M / US: F-78
5328A / EC6-50-A (1-1/4") 5327 / EA6-50 (1-1/4" Alu)	SPTC50AV114M / US: F-114
5328X / EC6-50-HF (1-1/4" Hiflex)	SPTC50AV114X
5438A / EC7-50-A (1-5/8")	SPTC50AV158M / US: F-158
5437 / EA7-50 (1-5/8" Alu)	







We strongly advise the use of cable preparation tools. Please refer to their instructions for use.

### Manual method

Follow the instruction process below only if the cable preparation tools are not available.



\* A Butyl mastic tape is available in our Weatherproofing Tape Kit (ref. 2849996)

	NM	7/16M	7/8"	1 1/4"	1 5/8"
	19 mm	32 mm	 30 mm	 1-11/16" /  $\phi$ 4 mm / $\phi$ 48 mm	 2-1/4" /  $\phi$ 5 mm / $\phi$ 63 mm

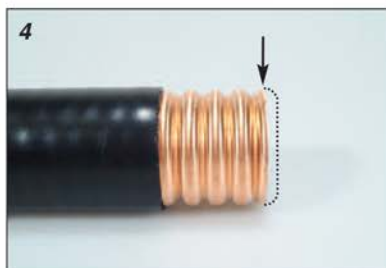
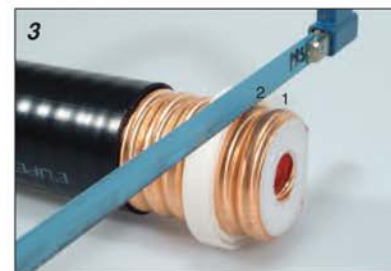
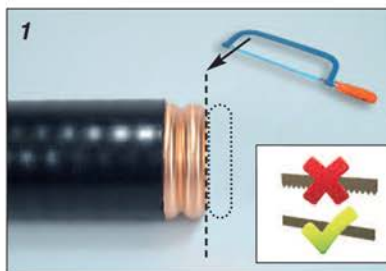



# INNOVATION & TRADITION

100 Years of Cable Manufacturing

## 7/8", 1-1/4" & 1-5/8" Connectors - N1 (O-ring)

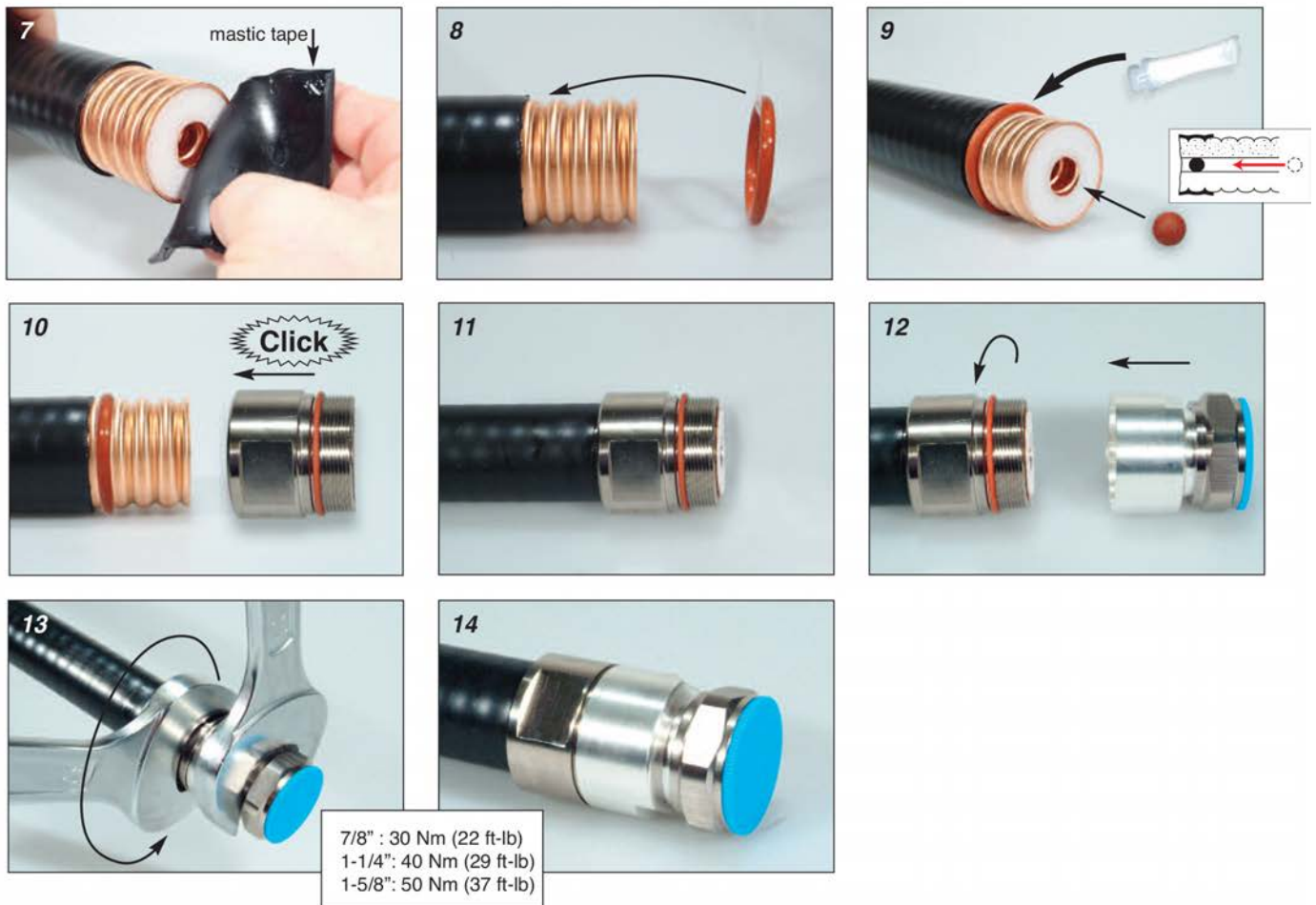

For the installation on aluminium cables 5227/EA5-50, 5327/EA6-50 and 5437/EA7-50 in a corrosive environment, an additional sealing is mandatory. It can be achieved with one of the following methods:

### Weatherproofing Tape Kit



### Eucaseal



### Cold Shrink Tube





## F-Series Cable Prep Tool Instructions



The Eupen F-Series Tool is a dual function, drill-mounted cable prep tool designed for use with Eupen MonoBlock connectors and Eupen feeder cable.

**ATTENTION:** Safety glasses and gloves should be worn at all times when operating drill-mounted tools. Always use tools in accordance with safety procedures and only for the intended purpose. Your safety program should include but should not be limited to standards of OSHA, NEC and NESC.

1. Begin with a STRAIGHT section of cable cut in the valley of corrugation for best results.



2. With the Jacket Cutter attached to the Trim Head, use a drill to turn the F-Series Tool onto the cable clockwise at low rpm.

Push slightly while the jacket is being cut until the tool stops forward travel and spins freely.



3. Remove tool from cable.  
**Note:** Outer jacket should be cut to peak of corrugation.

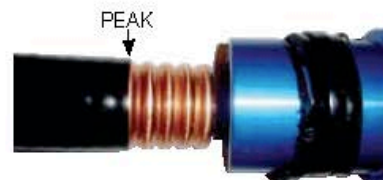

- 4A. Install O-ring in the valley next to the jacket cut.
- 4B. Install silicone rubber ball inside inner conductor. Apply grease as per connector instructions.

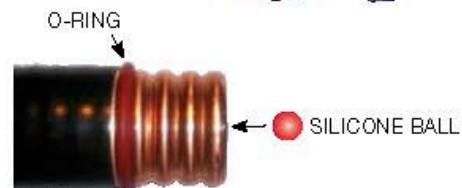

5. Install rear portion of connector over the O-ring, then pull forward so that the forward edge of the connector is covering the spring fingers and aligned over the corrugation peak.



## F-Series Cable Prep Tool Instructions

(continued)

6. Remove Jacket Cutter from Trim Head.  
(Hold Jacket Cutter firmly. Lift locking pin and separate from Trim Head).



7. Using drill turning clockwise on low RPM.  
Cut the end of the cable with the Trim Head.

The Trim Head will spin freely and bottom out on the connector body when the cut is complete.



LOW SPEED - CLOCKWISE



8. Complete connector installation as per connector instructions.



### REPLACEMENT PARTS

	F-78	F-114	F-158
Jacket Cutter Assembly	F-78-JCA	F-114-JCA	F-158-JCA
Trim Head Assembly	F-78-THA	F-114-THA	F-158-THA
Jacket Cutter Blade	SPB09	SPB12	SPB10
Trim Head Blade	SPB14	SPB14	SPB11
Pilot Pin	SPB03PP	SPB05PP	SPB01PP



## 1/2" EIA connectors EIA78V12N



EIA78V12N



EIA78CH = coupling hardware (sold separately)



EC4-50 (5128)

EIA
19 mm & 21 mm

Vaseline  
Vaselina  
凡士林

3M : F 04/013  
Abrasif  
Abrasive  
Schleifmittel  
Schnuurspons  
Abrasive  
磨石纸

saw-guide  
guide-scie  
Sägelehre

### Manual method

# INNOVATION & TRADITION

100 Years of Cable Manufacturing

## 1/2" EIA connectors EIA78V12N

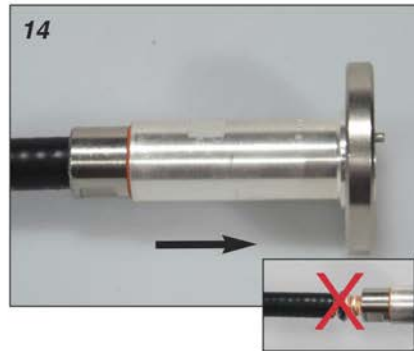
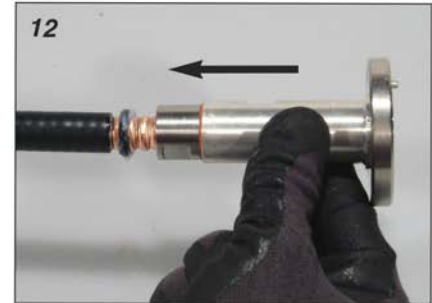

## EIA connectors for cables 7/8" to 1-5/8"



EIA78V78N



EIA78V114N

Coupling hardware  
(sold separately):



EIA78CH  
(for interface EIA 7/8")



<b>7/8"</b>	EC5-50-A (5228 A)
<b>1-1/4"</b>	EC6-50-A (5328 A)
<b>1-5/8"</b>	EC7-50-A (5438 A)



EIA78V158N





EIA158V158N



EIA158CH  
(for interface EIA 1-5/8")









Vaseline











Mastic tape\*



Saw-guide

\* A Butyl mastic tape is available in our Weatherproofing Tape Kit (ref. 2849996)

**7/8"**



24 mm  
30 mm

**1-1/4" & 1-5/8"**



φ 5 mm  
φ 63 mm

**Manual method**

**1**

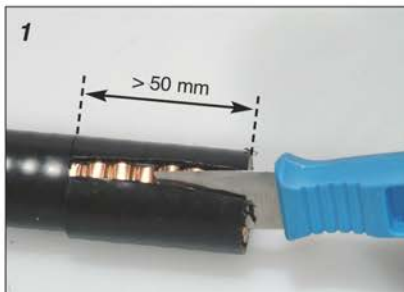

**2**

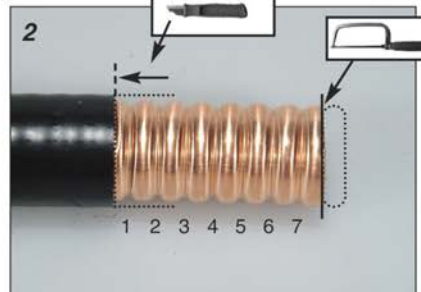

**3**

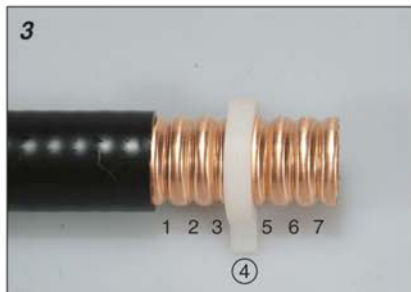

**4**



**5**

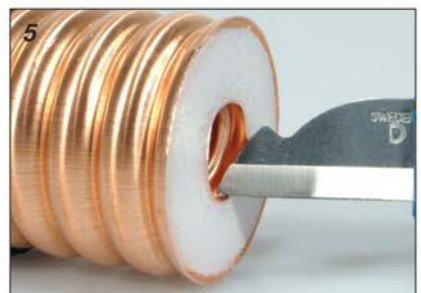

**6**



# INNOVATION & TRADITION

100 Years of Cable Manufacturing

## EIA connectors for cables 7/8" to 1-5/8"

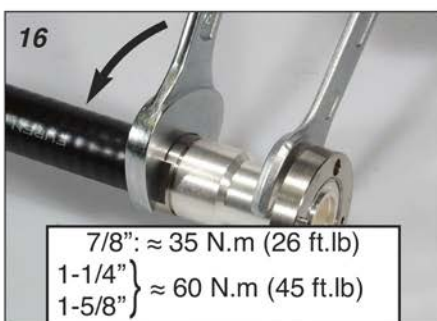
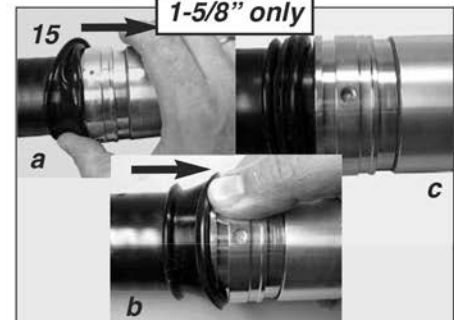
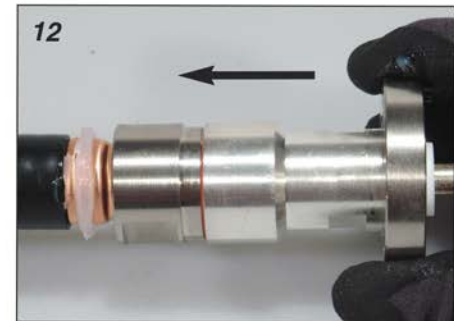
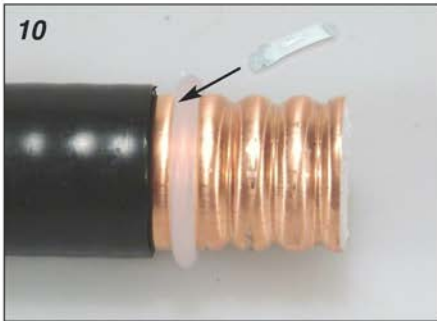
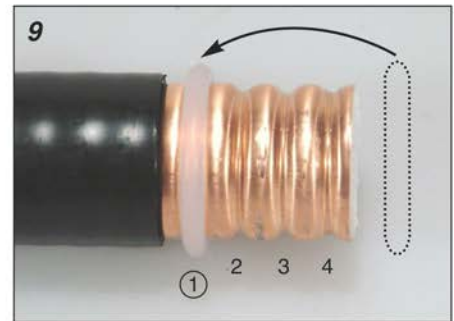
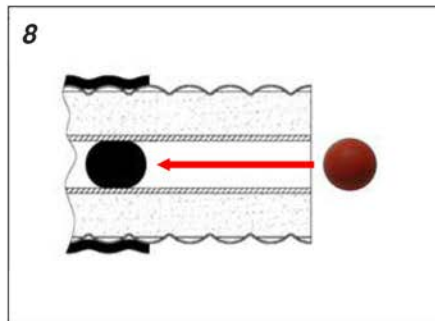
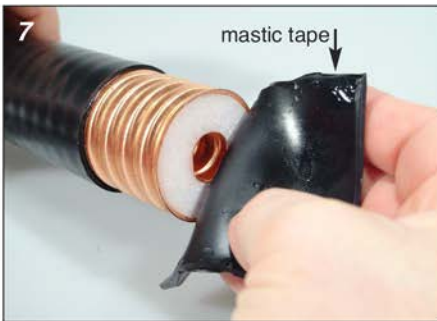



**EUPEN** Cable USA

**ELLIPTICAL WAVEGUIDE**  
Connector Installation Instructions

# Elliptical Waveguide Connector Installation Instructions

---

## SECTION 3

**EU52**

**EU63**

**EU77**

**EU90**

**EU127**





# INNOVATION & TRADITION

100 Years of Cable Manufacturing

## for Premium Waveguide Connectors with Profile Gasket

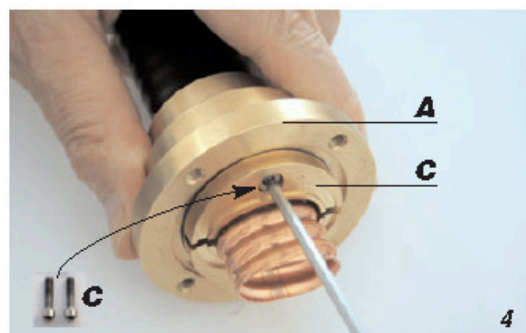
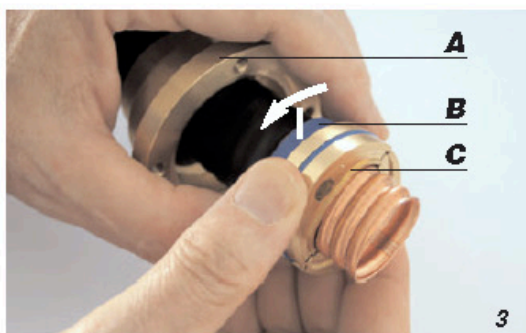
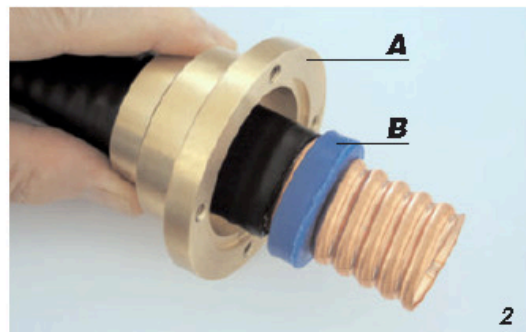
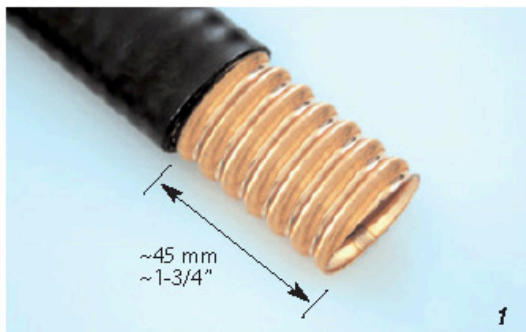
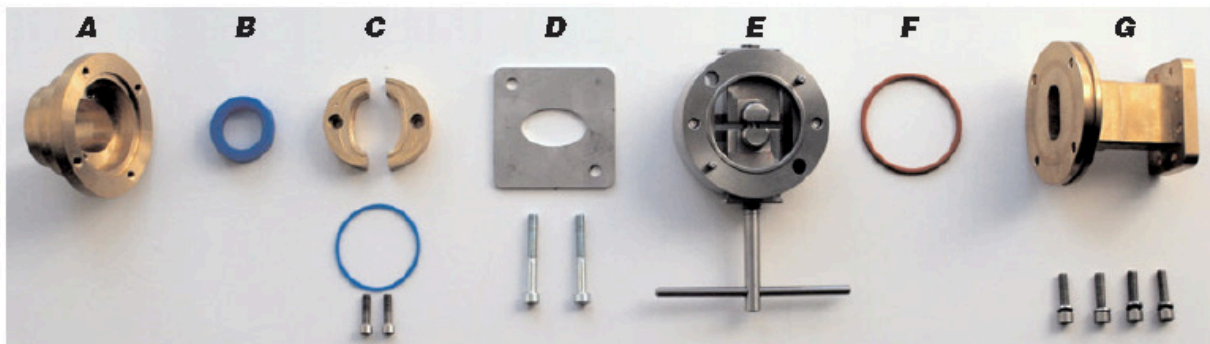

Our technician is not wearing gloves to increase clarity of pictures !!!

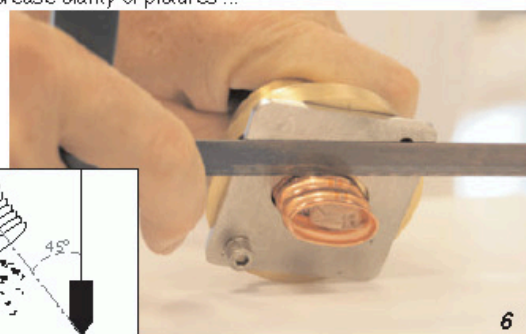
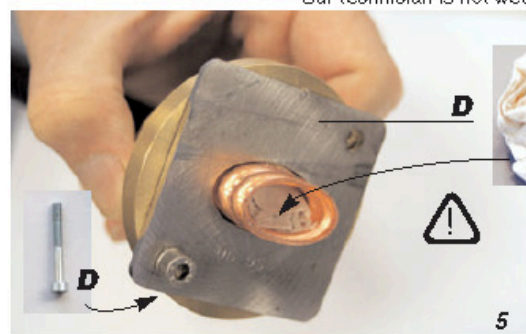

*for Premium Waveguide Connectors with Profile Gasket*

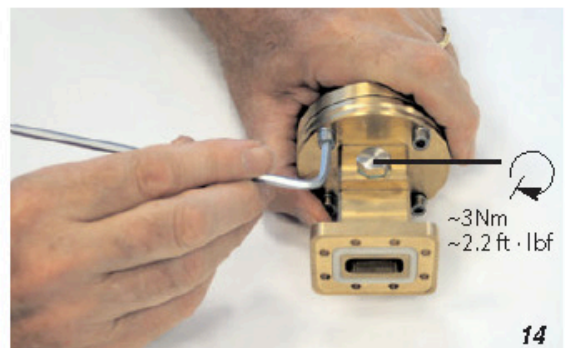
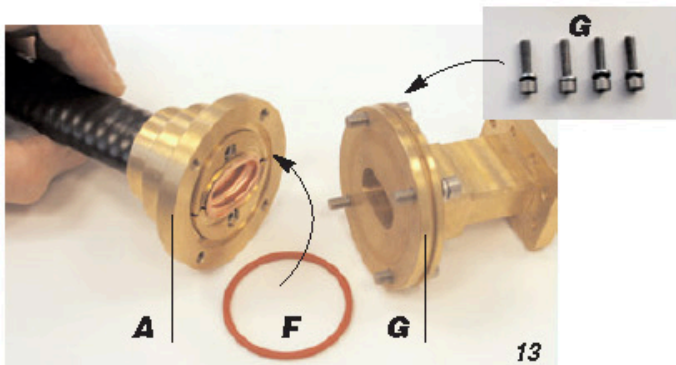
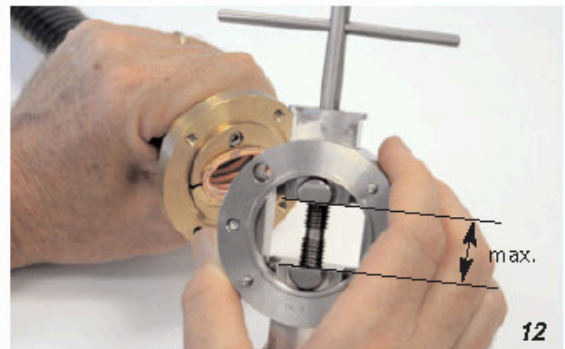
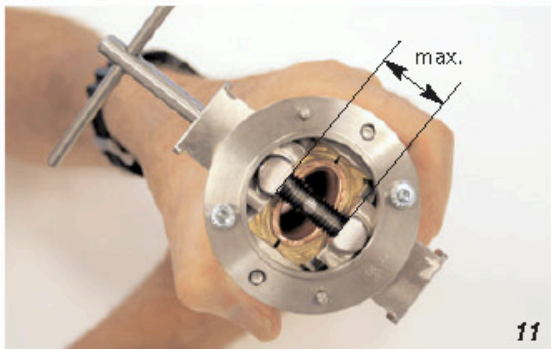
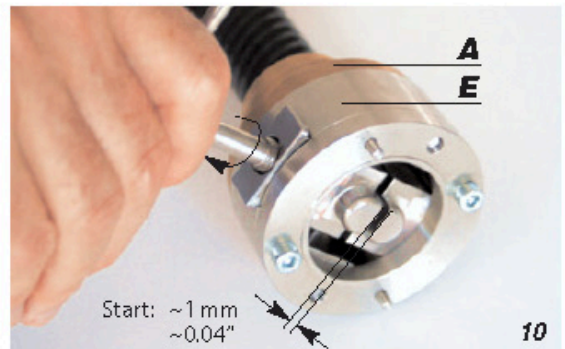
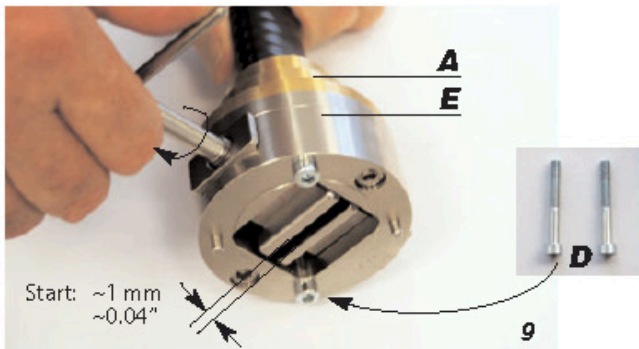
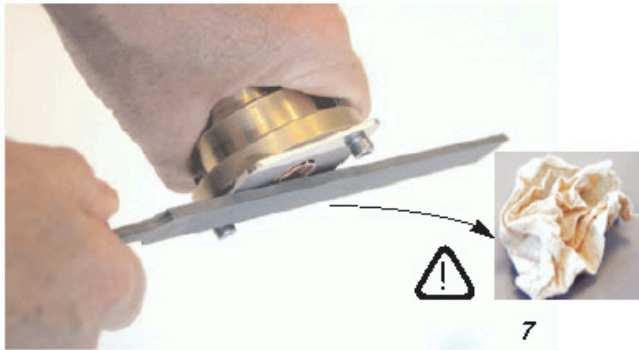

For outdoor application apply tape and/or shrinkboot

**INNOVATION & TRADITION**

100 Years of Cable Manufacturing

# Radiating Connector Installation Instruction Sheets

---

## SECTION 4

**1/2" Radiating**

**5/8" Radiating**

**7/8" Radiating**

**1-1/4" Radiating**

**1-5/8" Radiating**

**RC-400 Radiating**

**For more information on Eupen Radiating Products  
please contact your Eupen Sales Representative  
and also check out our Radiating web site at**

**[www.radiating-cables.com](http://www.radiating-cables.com)**



# RADIATING CONNECTOR

## Installation Instruction Sheets

### Connectors for 1/2" Radiating Cables



	<b>NF, 7-16F</b>	<b>NM</b>	<b>7-16M</b>
	2 x 22 mm	2 x 22 mm & 19 mm	2 x 22 mm & 32 mm

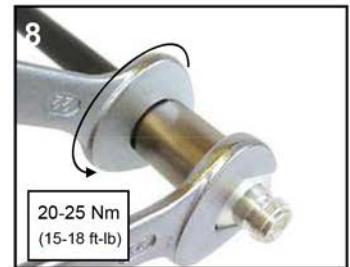
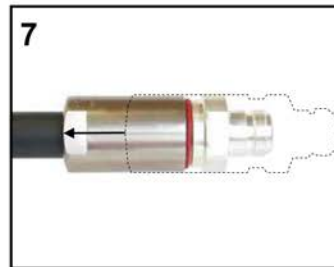
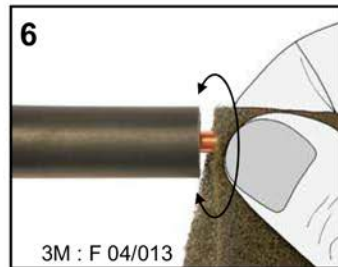
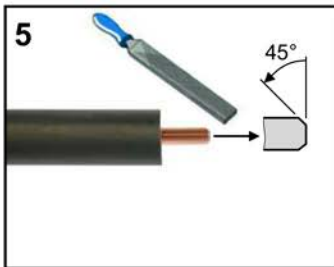
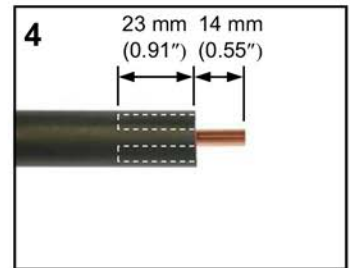
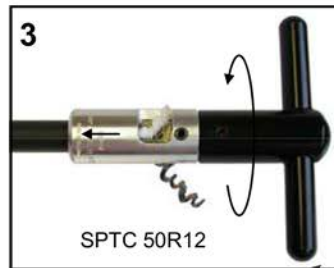
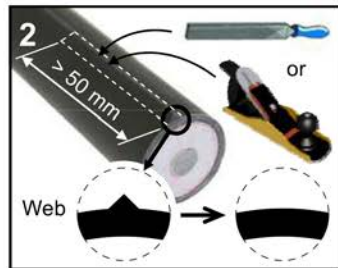
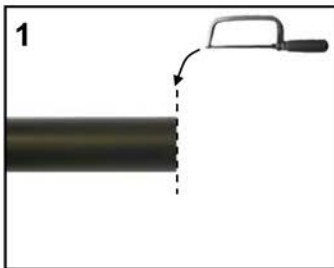
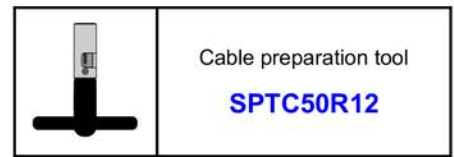

# INNOVATION & TRADITION

100 Years of Cable Manufacturing

## Connectors for 5/8" Radiating Cables



	<b>NM</b>	<b>7-16F/NF</b>
	2 x 28 mm & 19 mm	2 x 28 mm

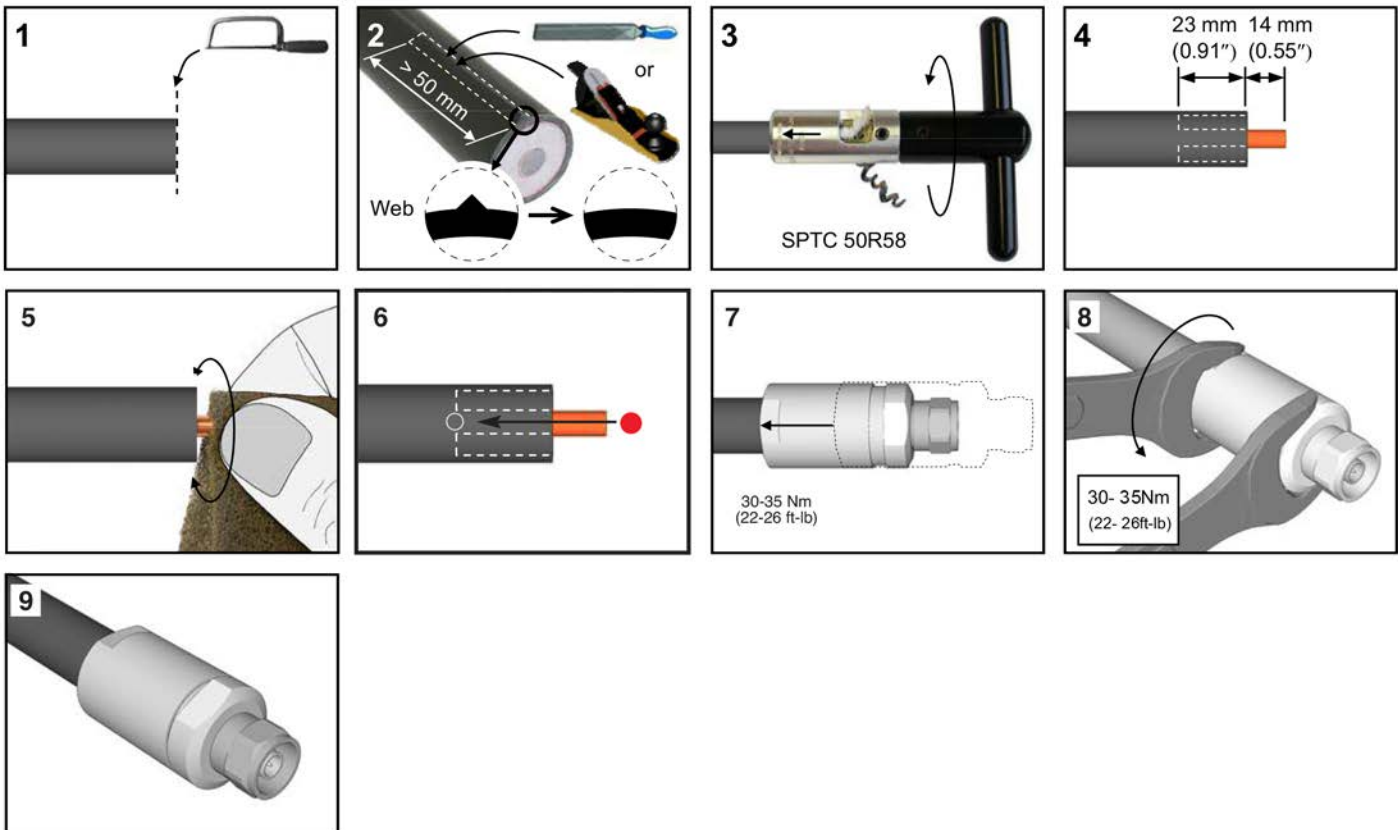
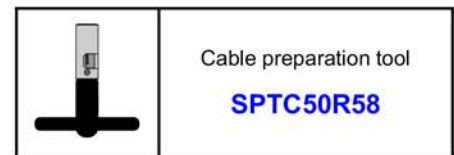

## Connectors for 7/8" Radiating Cables

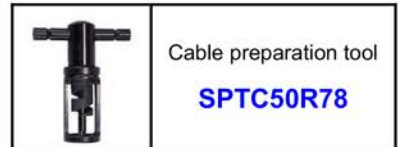

 ø 52 mm	NF, 7-16F	NM	7-16M
	2 x 34 mm	2 x 34 mm & 19 mm	2 x 34 mm & 32 mm

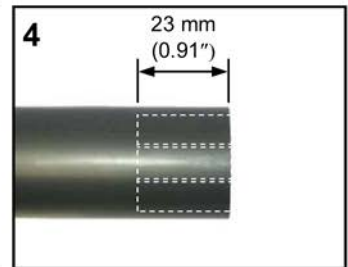
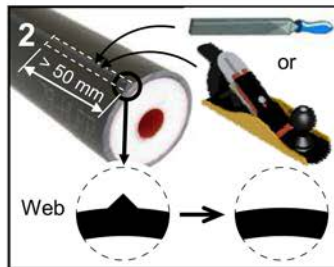
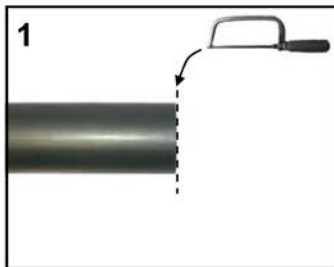

### Radiating cables with fire barrier tape

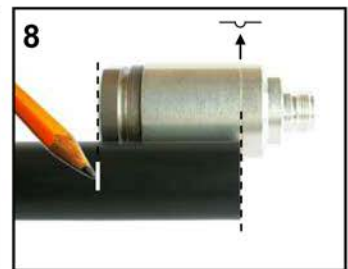
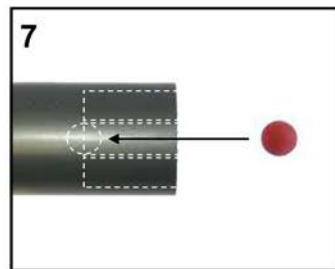
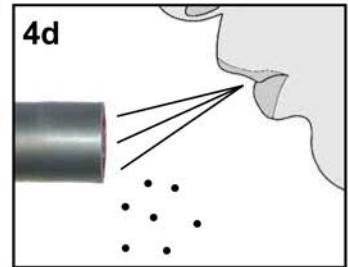
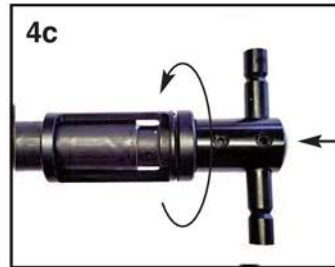
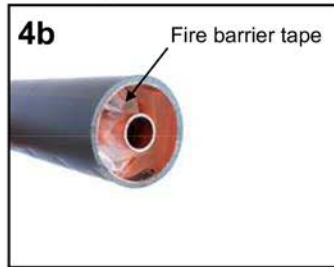
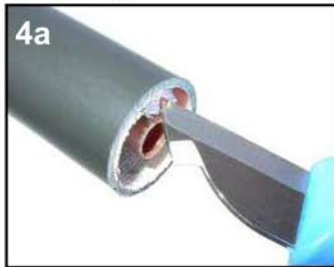

# INNOVATION & TRADITION

100 Years of Cable Manufacturing

## Connectors for 7/8" HLFRC & HLFRT Radiating Cables



 ø 52 mm	NF, 7-16F	NM	7-16M
	2 x 34 mm	2 x 34 mm & 19 mm	2 x 34 mm & 32 mm

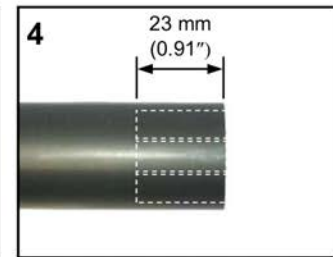
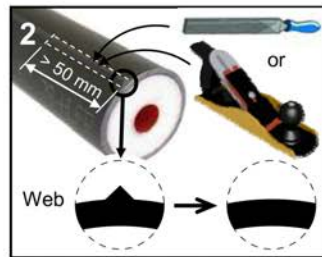
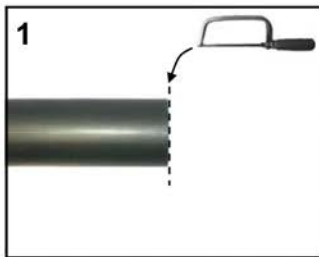

### Radiating cables with fire barrier tape

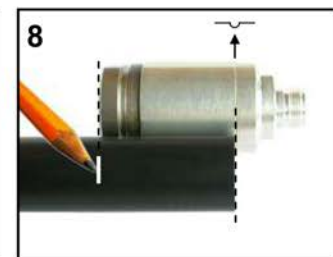
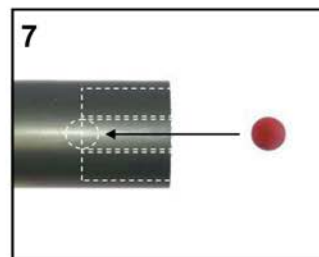
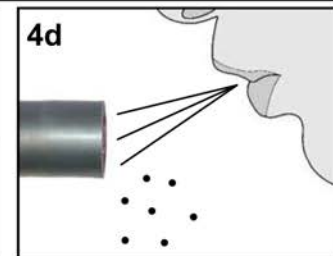
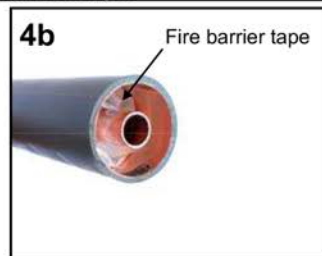

1\* For installations in harsh environments, the use of an optional Heat-Shrink is recommended.

## Connectors for 1-1/4" Radiating Cables



Tools: Wire brush, utility knife, side cutter, or剥线钳 (wire stripper).

$\phi$ 5 mm	NM	7-16M
$\phi$ 52 mm	19 mm	32 mm

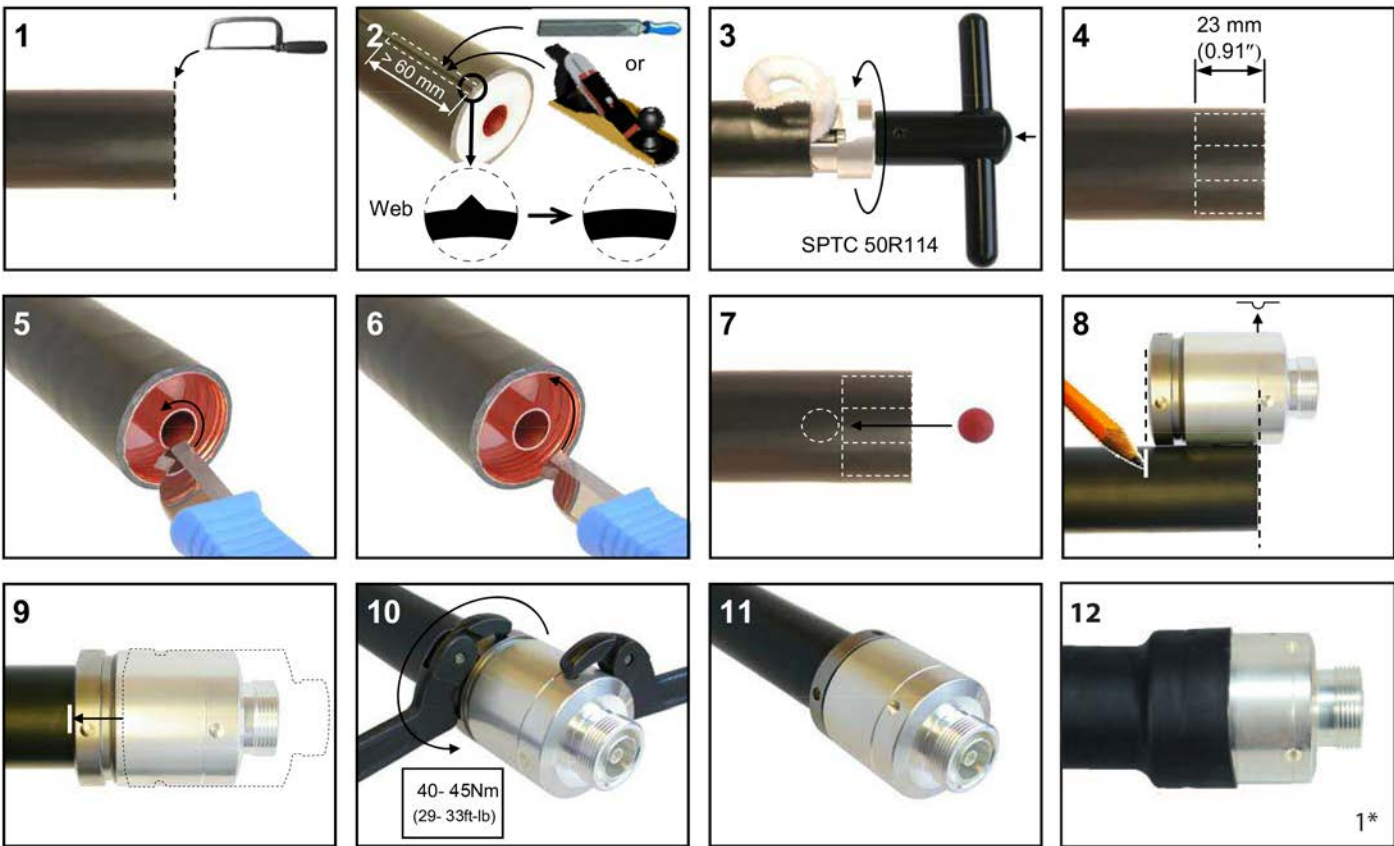

1\* For installations in harsh environments, the use of an optional Heat-Shrink is recommended.



# INNOVATION & TRADITION

100 Years of Cable Manufacturing

## Connectors for 1-1/4" HLFRL Radiating Cables

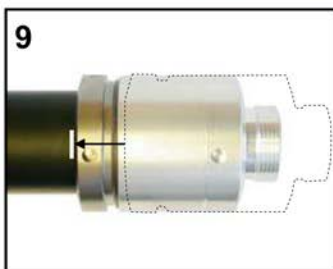
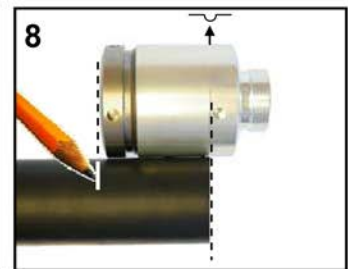
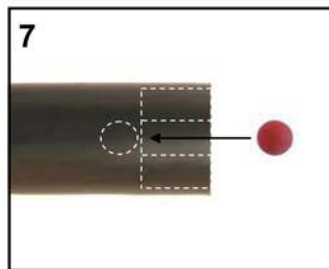
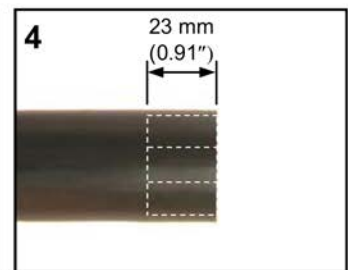
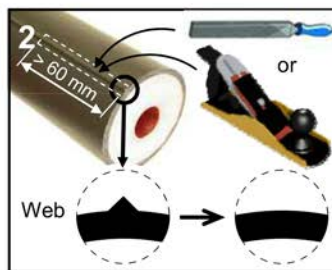
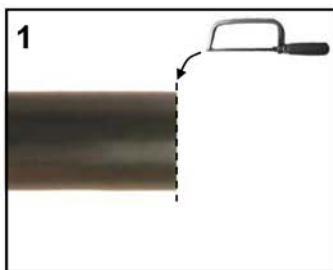
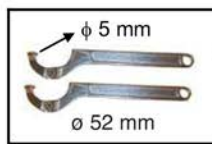
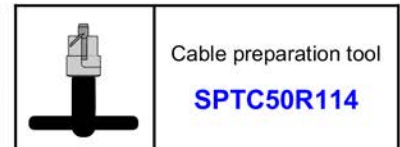

1\* For installations in harsh environments, the use of an optional Heat-Shrink is recommended.



**EUPEN** Cable USA

## Connectors for 1-5/8" Radiating Cables

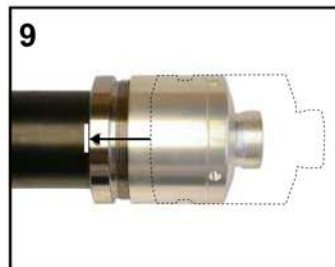
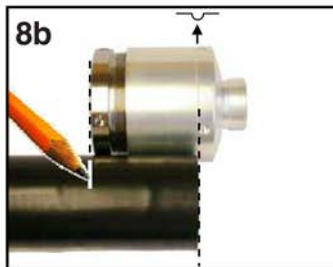
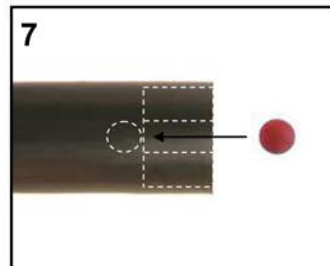
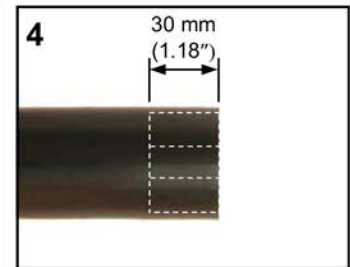
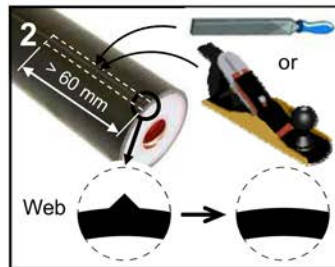
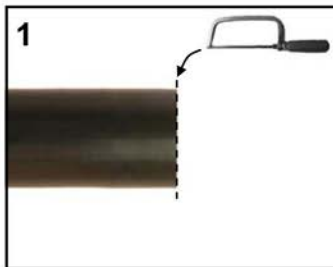
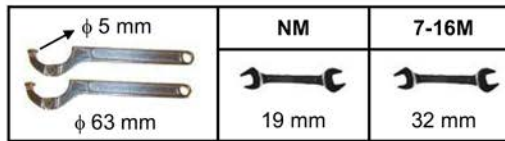
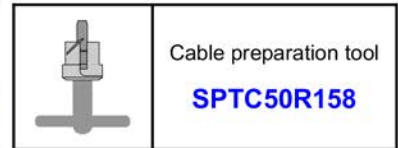

# INNOVATION & TRADITION

100 Years of Cable Manufacturing

## Connectors for RC-400 Radiating Cable

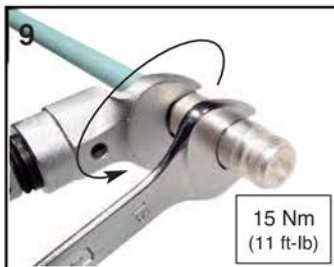
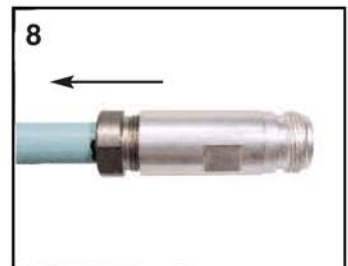
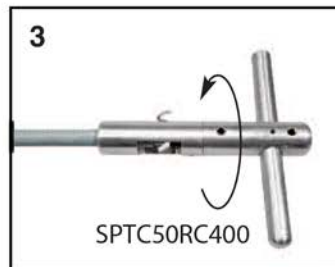
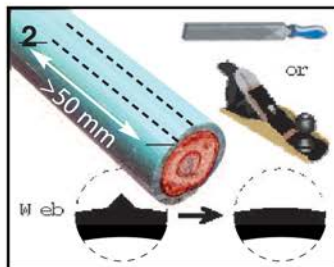
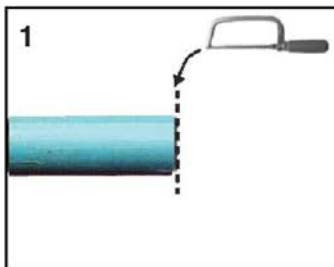
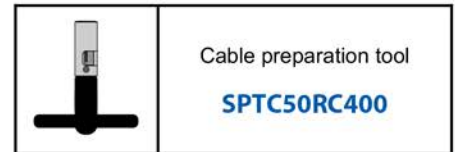
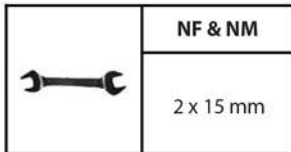

1\* For installations in harsh environments, the use of an optional Heat-Shrink is recommended.



**EUPEN** Cable USA



# Reference Sheets

## SECTION 4

### Cable/Connector Reference Sheet

### Jumper Part Number Description

### Prep Tool Selection Guide



# INNOVATION & TRADITION

100 Years of Cable Manufacturing

CABLE PART NUMBER	SIZE	CONNECTOR TYPE	TOOL PART NUMBER
EC1-50-HF	1/4" Hiflex	Hiflex	SPTC50B14X
EC4-50-HF	1/2" Hiflex	Hiflex	SPTC50B12X
		Rt Angle Hiflex	SPTC50BL12X
EC1-50	1/4"	Standard	SPTC50AV14
EC4-50	1/2"	Standard	SPTC50AV12
		Rt Angle Standard	
EC4-50-PL	1/2" Plenum	Standard	SPTC50AV12F
		Rt Angle Standard	
EC4.5-50	5/8"	Standard	SPTC50AV58
EC5-50-A	7/8"	N1	F-78
EC6-50-A	1-1/4"	N1	F-114
EC7-50-A	1-5/8"	N1	F-158



**EUPEN** Cable USA



## NOTES

# INNOVATION & TRADITION

100 Years of Cable Manufacturing

## NOTES



# **EUPEN** Cable USA

## **INNOVATION & TRADITION**

100 Years of Cable Manufacturing



**Fully Stocked and  
Conveniently Located Warehouses**

**Tampa Bay, Florida - North American Headquarters**

Bethlehem, PA

Dallas, TX

Ph: 800-419-5100 Fax: 727-528-0751  
5181 110th Ave N, Unit D, Clearwater, FL 33760  
[www.eupen.us](http://www.eupen.us) [customerservice@eupen.us](mailto:customerservice@eupen.us)

